



A WIDE DEVIATION RF PHASE MODULATOR

INTRODUCTION

The two most common approaches for analog phase modulators have been full phase deviation modulation at RF and frequency (and phase deviation) multiplication. An example of the second approach: 1) phase modulate a 10 MHz sub-carrier at .05 radians; 2) pass this signal through a nonlinear device (comb generator/step recovery diode) and 3) filter it with a bandpass filter centered at 200 MHz. The resultant RF signal has a one radian deviation @ 200 MHz. Both the sub-carrier frequency and phase deviation are multiplied by twenty. These traditional analog approaches have drawbacks. The full phase deviation approach suffers from limited deviation range and an exponential, not linear, transfer function from control voltage input to phase deviation output. The frequency multiplier approach is less affected by these limitations, but requires a complex bandpass filter at the final frequency to eliminate equal power harmonics that are offset by the sub-carrier frequency (190 MHz and 210 MHz in the example).

The Phase Modulator discussed in this paper utilizes a mixed signal approach combining both analog and digital signal techniques. The Mixed Signal Phase Modulator (MS PM) does not have the drawbacks of purely analog phase modulators. The hardware complexity and real estate requirements are about the same for both the traditional analog modulators and the MS PM. In addition, the MS PM has several advantages such as easily and accurately adjustable frequency and modulation index.

HISTORY

The earliest analog phase modulators are the full deviation types. See figure 1. A crystal oscillator (XO) generates the desired frequency and a voltage controlled phase shifter does the modulating. Typically, the phase shifter is a tuned tank circuit with a varactor (voltage controlled capacitor) as the tuning element. This approach has three major shortcomings:

1. With ideal components, the maximum phase deviation is $\pm 90^\circ$. In the real world, half that range would be doing very well. In most applications, $\pm 30^\circ$ is the maximum obtainable deviation.



2. The transfer function of the varactor (voltage to capacitance) is exponential. As a result, the transfer function of the phase shifter (control voltage to phase shift) is nonlinear.
3. The output amplitude varies as a function of phase deviation. The deviation is limited to values that allow the signal amplitude to remain within an acceptable range.

Solutions to these shortcomings include linearizing circuitry or multiple phase shifting elements. The drawback to these solutions is increased complexity.

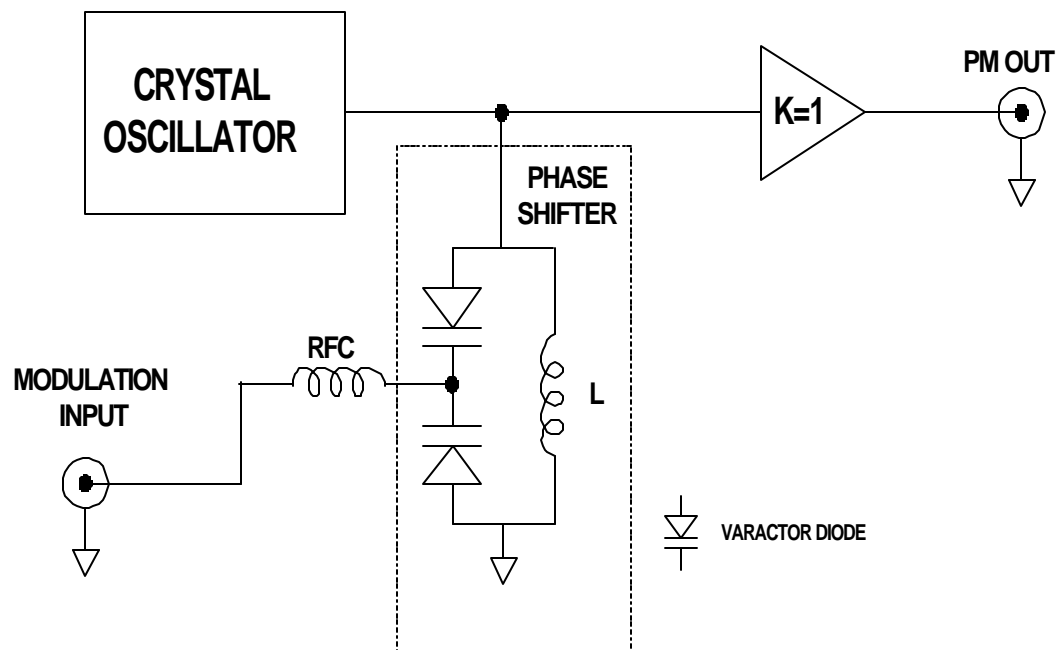

Figure 1 Full Deviation RF Phase Modulator



The frequency multiplication approach minimizes these problems, but requires complex bandpass filters. In the frequency multiplication approach, a sub-carrier at $1/N$ times the desired frequency is modulated at $1/N$ times the

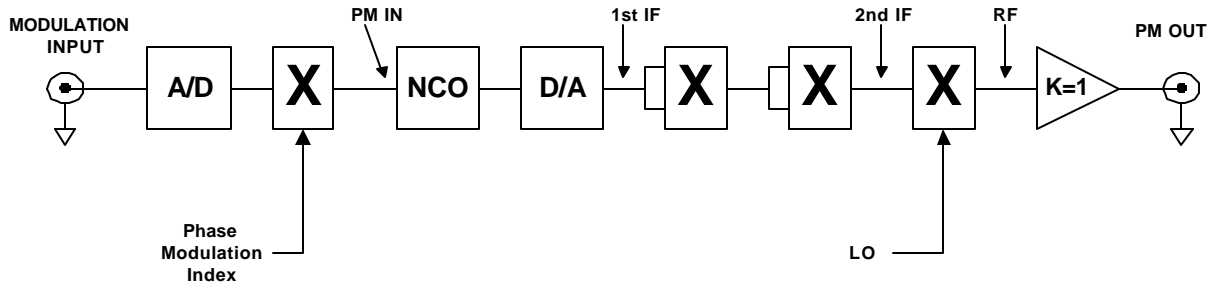

Figure 2 Mixed Signal Phase Modulator

desired deviation. This sub-carrier is input to a comb generator (step recovery diode) and a high-Q bandpass filter passes the N^{th} harmonic while all other harmonics are removed. The N^{th} harmonic is the desired phase modulated signal. Both the frequency and phase deviation of the original sub-carrier are multiplied by N (typically 10 to 30). The harmonics adjacent to the desired one are of equal power and very close to the desired frequency. This necessitates very high Q (50 and up) bandpass filters that are typically expensive and complex. The MS PM doesn't suffer from the shortcomings of either traditional analog approach.

THEORY OF OPERATION

The Mixed Signal Phase Modulator is an extension of the frequency multiplication approach. See figure 2. An NCO generates the first IF at one-fourth the desired phase deviation. This signal is input to a pair of cascaded linear multipliers configured as squarers. The output of the squarers is the second IF which is then frequency translated to RF. This RF signal has the desired phase deviation.

The input modulation signal is digitized in an A/D. This digital signal is input to a digital multiplier for Modulation Index scaling. The input signal is scaled so the output of the NCO has a deviation of one-quarter the desired value.



There are many advantages of an NCO over an analog Voltage Controlled Oscillator. These advantages include: easily and accurately set parameters (frequency and modulation index); linear transfer function from input signal to phase deviation output; and very good phase noise from an oscillator with a center frequency tunable over many decades. The only drawback of an NCO (with phase modulation) is maximum frequency, typically 10 MHz to 20 MHz.

The NCO output is applied to a D/A and is filtered to eliminate aliases. Two cascaded linear analog multipliers operating as squarers process this analog signal. The signal out of the squarers has the desired phase deviation but needs to be high pass filtered to eliminate the minus frequency terms. These filtering requirements are not very severe due to the large spread between the positive and negative terms of the multiplication and the fact that the multipliers are linear. With an ideal linear multiplier the harmonics and IM terms are nonexistent (down at least 30 dB in the real world). The output of the second squarer could be used as the modulated output. Typically, the maximum output frequency is limited to 50 MHz by the NCO. In the primary application, this signal is frequency translated to RF by a Local Oscillator (LO) and linear multiplier. In one application, the RF is used as the output. In another, it is up-converted to 2 GHz (S-Band).

CONCLUSION

The Mixed Signal Phase Modulator outperforms traditional (purely analog) phase modulators with no increase in complexity or real estate. By performing the phase modulation in the digital domain and using analog devices operating in their linear region, the MS PM does not suffer the inherent drawbacks of either traditional approach. In addition, the MS PM has several advantages such as a linear transfer function and easily set parameters (frequency and modulation index).